

Metal Furniture

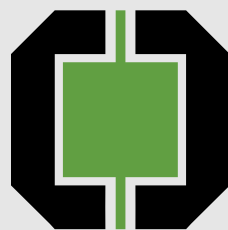

De Raat
security products

SOCIAL FURNITURE

SUM W WARDROBE LOCKERS

Wardrobe lockers allow to furnish social rooms in a functional and aesthetic way. Wide range of products guarantees fulfilling even the most varied users' needs. A modern design perforation system allows free air circulation. Welded construction based on closed profiles affects the rigidity of the lockers.

SUM W WARDROBE LOCKERS ARE MADE IN TWO WIDTHS:
 - 300 mm,
 - 400 mm (with internal partition wall to separate clean and dirty clothes).

- STANDARD EQUIPMENT:**
- a bar with hooks,
 - a hook for towel,
 - a mirror,
 - a self adhesive nameplate,
 - a shelf above the bar,
 - an internal partition (in 400 mm wide modules).



MEDALIST WARDROBES



a bar with hooks



a hook for towel



a mirror



a self adhesive nameplate



a shelf



an internal partition (in 400 mm wide modules)



SOCIAL FURNITURE

SUM W WARDROBE LOCKERS

Thanks to additional equipment our social lockers meet customer's requirements and expectations in 100%.

Slanted tops help maintain cleanness, socles and benches provide the functionality and ergonomics.

Seats of the benches consist of three wooden slats coated with clear varnish or three plastic slats.

All benches increase the height of the cabinet by 390 mm.



ADDITIONAL EQUIPMENT



slanted top



socle screwed to the lockers (140 mm high)



leg frame (140 mm high)



base without seat equipped with adjustable feet



base with seat equipped with adjustable feet



base with seat equipped with adjustable feet – economical version



extendable bench equipped with adjustable feet



base without seat equipped with adjustable feet – economical version

TYPES OF LOCKS

In social wardrobes it is possible to have a keylock (C) or a handle which is adapted to hang a padlock (D) on it.

It is possible to order lockers with MASTER key which allows opening certain number of locks.

Locks available at an extra cost:

- cylindrical moisture-resistant lock,
- coin locks (E) – return coin lock (F) or non-return coin locks (G),
- mechanical (H) and electronic code locks (I) and others – on customer's request.



MASTER key

3-point cylinder lock (A)



1-point cylinder lock (B)



SOCIAL FURNITURE

SUM W WARDROBE LOCKERS

ADVANTAGES OF SUM W WARDROBES:

- wide range of equipment as a standard,
- 16 colours at no extra cost,
- various types of locks to choose,
- socles, bases, legs, slanted tops etc.,
- increased usable space,
- seals of approval, certificates, declarations.



MEDALIST WARDROBES

ADVANTAGES OF SUM W WARDROBES



standard wide range of equipment



16 colours at no extra cost



various types of locks to choose



socles, bases, legs, slanted tops etc.



different price versions



seals of approval, certificates, declarations



SOCIAL FURNITURE

SUM W WARDROBE LOCKERS

SUM W Wardrobe lockers												
	Designation	Sum 310 W	Sum 311 W	Sum 320 W	Sum 321 W	Sum 330 W	Sum 331 W	Sum 340 W	Sum 341 W			
	Code	WSU 0101020102	WSU 0101020202	WSU 0102020102	WSU 0102020202	WSU 0103020102	WSU 0103020202	WSU 0104020102	WSU 0104020202			
	Height (mm)	1800	1940	1800	1940	1800	1940	1800	1940			
	Width (mm)	300		600		900		1200				
	Depth (mm)	500		500								
	Number of units	1		2		3		4				
	Number of doors	1		2		3		4				
	Legs	-	+	-	+	-	+	-	+			

SUM W Wardrobe lockers										
	Designation	Sum 410 W	Sum 411 W	Sum 420 W	Sum 421 W	Sum 430 W	Sum 431 W			
	Code	WSU 0201020103	WSU 0201020103	WSU 0202020103	WSU 0202020203	WSU 0203020103	WSU 0203020203			
	Height (mm)	1800	1940	1800	1940	1800	1940			
	Width (mm)	400		800		1200				
	Depth (mm)	500		500						
	Number of units	1		2		3				
	Number of doors	1		2		3				
	Legs	-	+	-	+	-	+			



SOCIAL FURNITURE

SUL W WARDROBE LOCKERS

In order to make use of small spaces such as cloak-rooms, an ideal solution is our L-shape wardrobe locker.

Thanks to SUL W wardrobe lockers, one can place twice as many wardrobe compartments as with wardrobe lockers.

Welded construction based on closed profiles affects the rigidity of the wardrobes.



ADVANTAGES OF SUL W WARDROBES



MEDALIST WARDROBES



standard wide range of equipment



16 colours at no extra cost



various types of locks to choose



socles, bases, legs, slanted tops etc.



different price versions



seals of approval, certificates, declarations

SOCIAL FURNITURE

SUL W WARDROBE LOCKERS

SUL W WARDROBE LOCKERS

SUL W wardrobe lockers are produced in two types of module width:

- 300 mm,
- 400 mm.

A modern design perforation system allows free air circulation.

Available locks: 1-point lock.



STANDARD EQUIPMENT



MEDALIST WARDROBES



1-point lock



a bar with hook



a self-adhesive nameplate



SOCIAL FURNITURE

SUL W WARDROBE LOCKERS

SUM W Wardrobe lockers												
	Designation	SUL 31 W	SUL 31 W	SUL 32 W	SUL 32 W	SUL 33 W	SUL 33 W	SUL 34 W	SUL 34 W			
Code	WSU 0306030104	WSU 0306030204	WSU 0306030204	WSU 0307030204	WSU 0308030104	WSU 0308030204	WSU 0309030104	WSU 0309030204				
Height (mm)	1800	1940	1800	1940	1800	1940	1800	1940				
Width (mm)	300		600		900		1200					
Depth (mm)	500		500									
Number of units	2		4		6		8					
Number of doors	2		4		6		8					
Legs	-	+	-	+	-	+	-	+				

SUM W Wardrobe lockers										
	Designation	SUL 41 W	SUL 41 W	SUL 42 W	SUL 42 W	SUL 43 W	SUL 43 W			
Code	WSU 0406030104	WSU 0406030204	WSU 0407030104	WSU 0407030204	WSU 0408030104	WSU 0408030204				
Height (mm)	1800	1940	1800	1940	1800	1940				
Width (mm)	400		800		1200					
Depth (mm)	500		500							
Number of units	2		4		6					
Number of doors	2		4		6					
Legs	-	+	-	+	-	+				



SOCIAL FURNITURE

SUS W WARDROBE LOCKERS

Lockers with compartments, thanks to their functionality, variety and aesthetic qualities can be used in a wide range of facilities, e.g. in cloakrooms, kindergartens, schools, boarding schools, swimming pools, fitness clubs, gyms, railway stations, workplaces - for storing briefcases, handbags, helmets etc.

Welded construction based on closed profiles affects the rigidity of the wardrobes.



ADVANTAGES OF SUS W WARDROBES



MEDALIST WARDROBES



standard wide range of equipment



16 colours at no extra cost



various types of locks to choose



socles, bases, legs, slanted tops etc.



different price versions



seals of approval, certificates, declarations

SOCIAL FURNITURE

SUS W WARDROBE LOCKERS - 300 mm wide module

Depending on customers' needs we offer different types of SUS W lockers with compartments:
 - 300 and 400 mm wide modules,
 - various number of compartments: from 2 up to 20.

A modern design perforation system allows free air circulation.



STANDARD EQUIPMENT

TECHNICAL SPECIFICATION



bar with hooks (in lockers with two compartments per module)

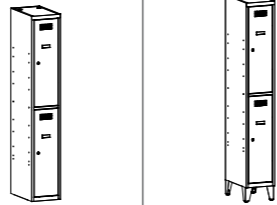
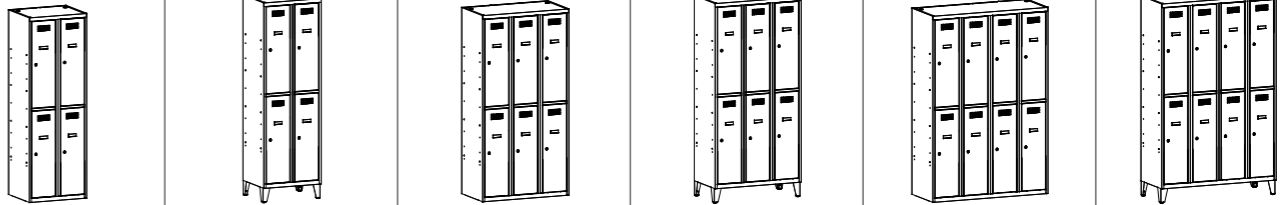

self adhesive nameplate

300 mm wide modules									
	Designation	SUS 312 W	SUS 312 W n	SUS 322 W	SUS 322 W n	SUS 332 W	SUS 332 W n	SUS 342 W	SUS 342 W n
Code	WSU 0106020104	WSU 0106020204	WSU 0107020104	WSU 0107020204	WSU 0108020104	WSU 0108020204	WSU 0109020104	WSU 0109020204	WSU 0109020204
Height (mm)	1800	1940	1800	1940	1800	1940	1800	1940	1940
Width (mm)	300		600		900		1200		
Depth (mm)	500		500						
Number of units	1		2		3		4		
Number of doors	2		4		6		8		
Legs	-	+	-	+	-	+	-	+	+

SOCIAL FURNITURE

SUS W WARDROBE LOCKERS - 300 mm wide module

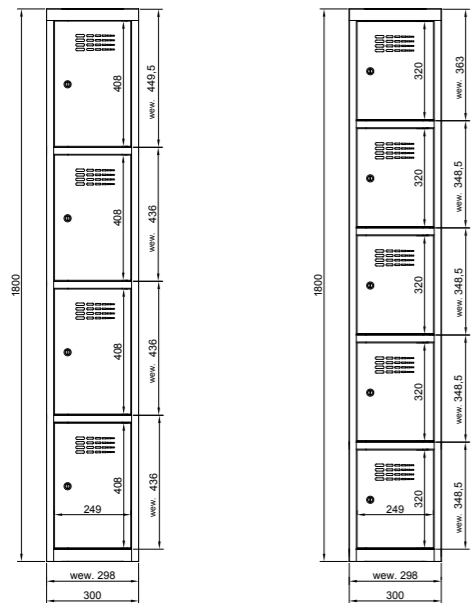
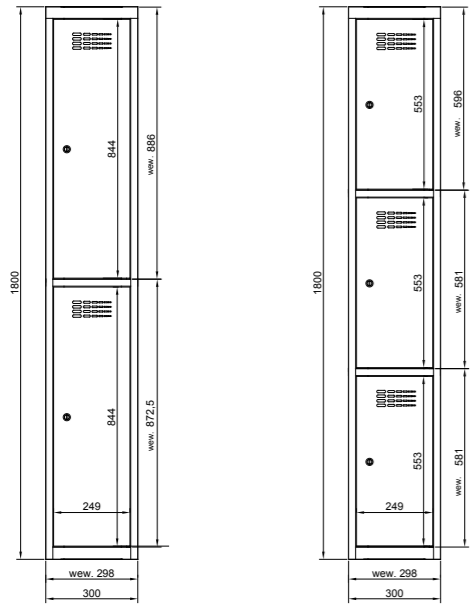

300 mm wide modules								
	Designation	SUS 313 W	SUS 313 W n	SUS 323 W	SUS 323 W n	SUS 333 W	SUS 333 W n	SUS 343 W
Code	WSU 0111020101	WSU 0111020201	WSU 0112020101	WSU 0112020201	WSU 0113020101	WSU 0113020201	WSU 0114020101	WSU 0114020201
Height (mm)	1800	1940	1800	1940	1800	1940	1800	1940
Width (mm)	300		600		900		1200	
Depth (mm)	500		500					
Number of units	1		2		3		4	
Number of doors	3		6		9		12	
Legs	-	+	-	+	-	+	-	+

300 mm wide modules								
	Designation	SUS 314 W	SUS 314 W n	SUS 324 W	SUS 324 W n	SUS 334 W	SUS 334 W n	SUS 344 W
Code	WSU 0116020101	WSU 0116020201	WSU 0117020101	WSU 0117020201	WSU 0118020101	WSU 0118020201	WSU 0119020101	WSU 0119020201
Height (mm)	1800	1940	1800	1940	1800	1940	1800	1940
Width (mm)	300		600		900		1200	
Depth (mm)	500		500					
Number of units	1		2		3		4	
Number of doors	4		8		12		16	
Legs	-	+	-	+	-	+	-	+

300 mm wide modules								
	Designation	SUS 315 W	SUS 315 W n	SUS 325 W	SUS 325 W n	SUS 335 W	SUS 335 W n	SUS 345 W
Code	WSU 0121020101	WSU 0121020201	WSU 0122020101	WSU 0122020201	WSU 0123020101	WSU 0123020201	WSU 0124020101	WSU 0124020201
Height (mm)	1800	1940	1800	1940	1800	1940	1800	1940
Width (mm)	300		600		900		1200	
Depth (mm)	500		500					
Number of units	1		2		3		4	
Number of doors	5		10		15		20	
Legs	-	+	-	+	-	+	-	+

SOCIAL FURNITURE







SUS W WARDROBE LOCKERS
- 400 mm wide module

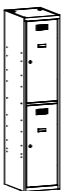

TECHNICAL SPECIFICATION

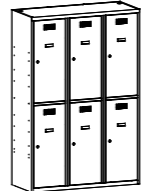

MEDALIST WARDROBES

400 mm wide modules						
Designation	SUS 412 W	SUS 412 W n	SUS 422 W	SUS 422 W n	SUS 432 W	SUS 432 W n
Code	WSU 0206020104	WSU 0206020204	WSU 0207020104	WSU 0207020204	WSU 0208020104	WSU 0208020204
Height (mm)	1800	1940	1800	1940	1800	1940
Width (mm)	400		800		1200	
Depth (mm)	500		500			
Number of units	1		2		3	
Number of doors	2		4		6	
Legs	-	+	-	+	-	+

SOCIAL FURNITURE

SUS W WARDROBE LOCKERS - 400 mm wide module

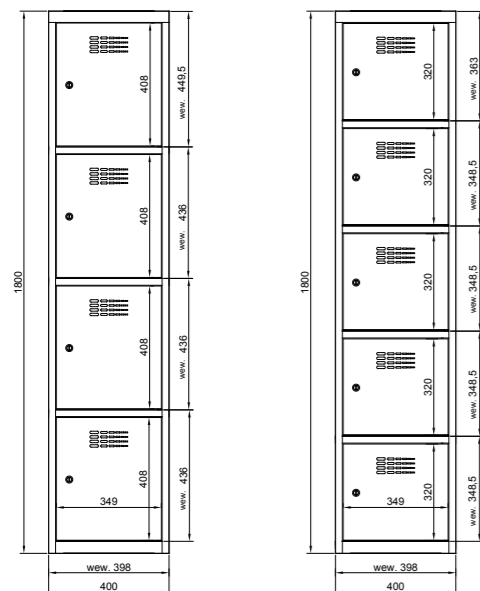
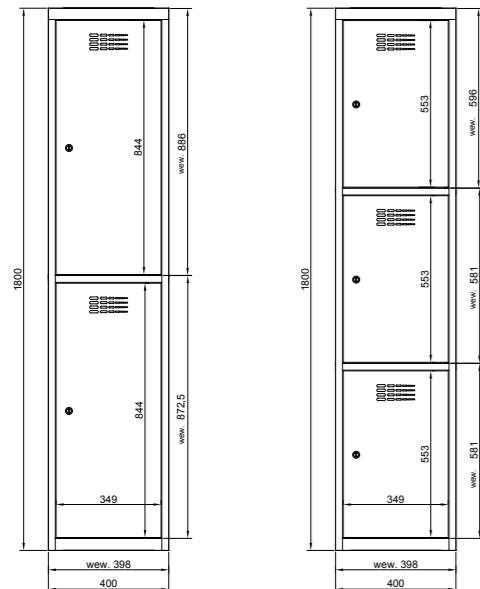

400 mm wide modules						
Designation	SUS 413 W	SUS 413 W	SUS 423 W	SUS 423 W	SUS 433 W	SUS 433 W
Code	WSU 0211020101	WSU 0211020201	WSU 0212020101	WSU 0212020201	WSU 0213020101	WSU 0213020201
Height (mm)	1800	1940	1800	1940	1800	1940
Width (mm)	400		800		1200	
Depth (mm)	500		500			
Number of units	1		2		3	
Number of doors	3		6		9	
Legs	-	+	-	+	-	+

400 mm wide modules						
Designation	SUS 414 W	SUS 414 W	SUS 424 W	SUS 424 W	SUS 434 W	SUS 434 W
Code	WSU 0216020101	WSU 0216020201	WSU 0217020101	WSU 0217020201	WSU 0218020101	WSU 0218020201
Height (mm)	1800	1940	1800	1940	1800	1940
Width (mm)	400		800		1200	
Depth (mm)	500		500			
Number of units	1		2		3	
Number of doors	4		8		12	
Legs	-	+	-	+	-	+

400 mm wide modules						
Designation	SUS 415 W	SUS 415 W	SUS 425 W	SUS 425 W	SUS 435 W	SUS 435 W
Code	WSU 0221020101	WSU 0221020201	WSU 0222020101	WSU 0222020201	WSU 0223020101	WSU 0223020201
Height (mm)	1800	1940	1800	1940	1800	1940
Width (mm)	400		800		1200	
Depth (mm)	500		500			
Number of units	1		2		3	
Number of doors	5		10		15	
Legs	-	+	-	+	-	+



SOCIAL FURNITURE

SLANTED TOPS AND SOCLES FOR WSU WARDROBE LOCKERS

Wardrobe lockers can be equipped with slanted tops that help to maintain cleanness in social spaces.

- Slanted tops help to maintain the cleanness on top of the locker by making it easy to sweep and to dust.
- Simple assembly - with latches.



TECHNICAL SPECIFICATION

Slanted tops						
	Designation	D310 W	D320 W	D330 W	D410 W	D420 W
Code	DWSU 010101	DWSU 010102	DWSU 010103	DWSU 020101	DWSU 020102	DWSU 020103
Height (mm)	200		200			
Width (mm)	300	600	900	400	800	1200
Depth (mm)	500		500			

Socles							
	Designation	C310 W	C320 W	C330 W	C340 W	C410 W	C420 W
Code	CWSU 010101	CWSU 010102	CWSU 010103	CWSU 010104	CWSU 020101	CWSU 020102	CWSU 020103
Height (mm)	140		140				
Width (mm)	300	600	900	1200	400	800	1200
Depth (mm)	450		450				



SOCIAL FURNITURE

BENCHES FOR WSU WARDROBE LOCKERS

Cabinets can be placed on benches, and then fixed with screws.

The seat consists of three wooden slats coated with clear varnish or plastic slats, especially recommended for use in wet environments.

We offer 2 price versions:

- standard (frames and legs are made of closed profiles),
- economic (frame is made of bent steel sheet, legs of closed profiles).

In our offer, we have very practical, extendable benches which help to save space. These benches are ideal where it is essential to organize a space effectively. The bench has an extendable seat, which fits under the wardrobe.

Bench with legs								
	WCn 311 W	WCn 321 W	WCn 331 W	WCn 341 W	WCn 411 W	WCn 421 W	WCn 431 W	
	PWSU 09020101	PWSU 09020201	PWSU 09020301	PWSU 09020401	PWSU 10020101	PWSU 10020201	PWSU 10020301	
	140		140		140		140	
	275	575	875	1175	375	775	1175	
450		450		450		450		

One-side benches											
	P311 W	P321 W	P321 W	P 331 W	P411 W	P 421 W	P 431 W				
	PWSU 01010102	PWSU 01010103	PWSU 01010202	PWSU 01010302	PWSU 01010303	PWSU 02010102	PWSU 02010103	PWSU 02010202	PWSU 02010203	PWSU 02010302	PWSU 02010303
	390		390		390		390		390		
	290	590	590	890	390	790	1190				
745		745		745		745		745			
+		+		+		+		+			
	+		+		+		+		+		

One-side benches – economic version											
	P313 W	P323 W	P323 W	P 333 W	P413 W	P 423 W	P 433 W				
	PWSU 05010102	PWSU 05010103	PWSU 05010202	PWSU 05010302	PWSU 05010303	PWSU 06010102	PWSU 06010103	PWSU 06010202	PWSU 06010302	PWSU 06010203	PWSU 06010303
	390		390		390		390		390		
	290	590	590	890	390	790	1190				
745		745		745		745		745			
+		+		+		+		+			
	+		+		+		+		+		



SOCIAL FURNITURE

BENCHES FOR WSU WARDROBE LOCKERS

Benches without a seat							
	Designation	P311 W	P321 W	P331 W	P411 W	P421 W	P431 W
	Code	PWSU 01010101	PWSU 01010201	PWSU 01010301	PWSU 02010101	PWSU 02010201	PWSU 02010301
	Height (mm)	390	390				
	Width (mm)	290	590	890	390	790	1190
Depth (mm)	490	490					

Benches without a seat – economical version							
	Designation	P313 W	P323 W	P333 W	P413 W	P423 W	P433 W
	Code	PWSU 05010101	PWSU 05010201	PWSU 05010301	PWSU 06010101	PWSU 06010201	PWSU 06010301
	Height (mm)	390	390				
	Width (mm)	290	590	890	390	790	1190
Depth (mm)	490	490					

Extendable benches												
	Designation	Pw311 W	Pw321 W	Pw321 W	Pw331 W	Pw411 W	Pw421 W	Pw431 W				
	Code	PWSU 07010102	PWSU 07010103	PWSU 07010202	PWSU 07010302	PWSU 07010303	PWSU 08010102	PWSU 08010103	PWSU 08010202	PWSU 08010203	PWSU 08010302	PWSU 08010303
	Height (mm)	390			390							
	Width (mm)	290	590	590	890	390	790	1190				
	Depth (mm)	745			745							
	Wooden slats	+		+	+		+		+		+	
Plastic slats		+		+		+		+		+		

SOCIAL FURNITURE

SCHOOL LOCKERS

School lockers are made of top quality steel. The bottom of the locker is made of galvanized steel to additionally protect it from corrosion. We use powder coatings from leading global manufacturers. Wide range of standard colours – 16 RAL colours.

As a standard we offer 1- or 3-points locking cylinder locks (in selected products). It is also possible to order other locks, according to individual needs. Most of our school lockers can be produced with legs or be placed on benches. Our lockers have declarations and certificates of compliance with Polish and European norms, as well as hygienic certificate issued by PZH (National Institute of Public Health).

1450 mm high school locker is designed for younger pupils. In doors of the lockers there are ventilation holes allowing for free exchange of air.

Lockers with compartments are made in different price versions – depending on thickness and type of steel sheet of which they are made (including galvanized or acid-proof steel).

We also offer lockers with compartments with additional equipment as follows:

- a bar with hooks,
- a book shelf for notebooks, handheld things, etc.



ADVANTAGES OF SCHOOL LOCKERS



standard wide range of equipment



16 colours at no extra cost



various types of locks to choose



socles, bases, legs, slanted tops etc.



different price versions



seals of approval, certificates, declarations

SOCIAL FURNITURE

SCHOOL LOCKERS

SUM S LOCKERS FOR PRE-SCHOOLERS

In our offer we also have 1350 mm high Sum S lockers for kindergarteners. Even the youngest children will be able to hang their clothes and reach the shelves without any effort.

Cloakrooms in kindergarten equipped with wardrobe lockers enhance kids' independence. Children who have their own individual lockers more willingly and actively prepare to their classes.

The standard locker is equipped with 1-point cylinder lock.

Other options of the lock:

- 3-point lock,
- a handle with magnetic closure.

SUM S LOCKERS FOR 6-YEAR-OLDS

Sum S locker is 1500 mm high, so younger children have more space compared to Sus lockers with compartments, and they can hang their clothes and reach shelves easily. Locker is equipped with a bar with hooks, a hook on doors and shelves for books, notebooks and handheld things.



TECHNICAL SPECIFICATION

SUM S CABINETS for preschoolers		
	Designation	SumS 310
Code	SUM 1702020510	SUM 1802020510
Height (mm)	1500	
Width (mm)	300	600
Depth (mm)	500	
Number of units	1	2
Number of doors		

Designation	SumS 330	SumS 340
Code	SUM 1902020510	SUM 2002020510
Height (mm)	1500	
Width (mm)	900	1200
Depth (mm)	500	
Number of units	3	4
Number of doors		

SUM S Locker for 6-year-olds				
	Designation	SumS 310p	SumS 320p	SumS 330p
Code	SUM 1703040112	SUM 1803040112	SUM 1903040112	SUM 2003040112
Height (mm)	1350		1350	
Width (mm)	300	600	900	1200
Depth (mm)	500			
Number of units	1	2	3	4
Number of doors				

SOCIAL FURNITURE







SCHOOL LOCKERS

We offer also different types of the lockers with original perforations of the doors, with various heights: 1560 mm, 1650 mm. These lockers are a part of additional offer for the customers who appreciate uniqueness, reliability and high quality.

It is just a sample of our possibilities. We are able to produce almost every your request!



TECHNICAL SPECIFICATION

WFD School lockers	 		   				
	Designation	WFD DFD 422350	WFD DFD 432350	WFD DFD 421350	WFD DFD 431350	WFD GS 2	WFD GS 3
Code	SFDB 2407220210	SFDB 2408220210	SFDB 2402220209	SFDB 2403220209	SFDB 2202200308	SFDB 2203200308	
Height (mm)	1560		1560		1650		
Width (mm)	725	1075	725	1075	625	925	
Depth (mm)	500		500		450		
Equipment	reinforced doors with opening limiter, a shelf		reinforced doors with opening limiter, top and bottom shelf, a bar, perforated bottom		reinforced doors with opening limiter, top and bottom shelf, a bar		

SOCIAL FURNITURE

LAPTOP/TABLET TROLLEYS

Trolley for laptops with function of battery charging is used to storage and easy transport of laptops. It is ideal for schools, colleges, libraries, conference halls, or anywhere where there is a need for secure storage and simultaneous laptops charging. WNL trolley is particularly useful in a classroom, where students need to charge laptops and store them safely. Thanks to the WNL trolley one can easily and safely move laptops from one class to another.

WNL trolley is used to store, secure and charge simultaneously from 10 to 30 laptops.

For the overload protection the sequencer is used, which enables to turn on the particular power strips after the specified time (~3 minutes) which results in a low maintenance of electrical load of the trolley during the charging process. A light-emitting diode is signalling the work of power strips of the laptop trolley.



Doors of the trolley are protected against unauthorized access by a key lock with locking in two points.

WNL Laptop Trolley was awarded the European Medal.



MEDALIST TROLLEYS

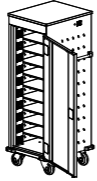
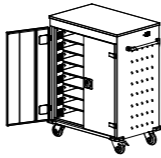

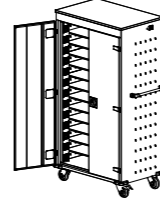
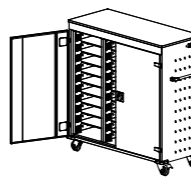
Laptop/tablet trolleys					
Designation	WNL 110	WNL 208	WNL 210	WNL 213	WNL 310
Code	WNL 0514060204	WNL 0615050404	WNL 0614050404	WNL 0616050404	WNL 0714050404
Height (mm)	1250	1060	1250	1540	1250
Width (mm)	530	920	920		1310
Depth (mm)	500		500		
Number of compartments	10	16	20	26	30



The trolley's top is covered with melamine. The frame has holes, for air circulation. Maximum laptop size: 90 x 340 x 470 mm (17 inch).

The trolley frame is made of polyster-epoxy painted metal.

Trolley has a Certificate of Compliance with European Directive 2001/95 concerning product safety.



Work safety

A sequencer and 2 fuses to protect against overloaded lines. Trolley has a Certificate of Compliance with European Directive 2001/95 concerning product safety.



Mobility

Easy to move thanks to 100 mm diameter swivel wheels covered with non-marking rubber (2 of them with brakes).



Ergonomics

Handles mounted on both sides and a top make the trolley easy to use.



Security

Doors of the trolley are secured with a key lock blocking it in 2 points. Trolley's side edges are secured with rubber corners.

SCHOOL FURNITURE E-CLASS

TABLET TROLLEYS

Tablet trolley with function of battery charging is used to store and transport 32 tablets + 1 laptop. It is ideal for schools, colleges, libraries, conference rooms – anywhere where there is a need for secure storage and simultaneous tablets charging.

The trolley is equipped with:

- socket to charge the laptop,
- two cables: with IEC C5 and IEC C7 output,
- inserts made out of incombustible foam allowing to store 32 tablets (maximal size 12x205x295 mm, ~12,2"),
- numbered compartments,
- a shelf (100x340x520 mm) with a socket for laptop,
- handles on both sides,
- four 100 mm diameter swivel wheels (made out of non-marking rubber) of 150 kg load capacity per wheel, two of them with breaks,
- bottom sides covered with melamine,
- doors with 2-point lock,
- melamine top (18 mm thick, with cut corners, with black scaleboards),
- ventilation holes for air circulation in the body,
- three-metre-long supply cable,
- handle on the side for reel of supply cable.

WNT Trolley's advantages:

- possibility of simultaneous charge of up to 32 devices (tablet, smartphone and additionally one laptop),
- each USB port equipped with LED diode confirming correctness of work,
- double circuit-breaker protection and protection against overload,
- protection against overheating,
- implementation of single loading time limiter (up to 5 hours) to safe the batteries of currently charging devices and to decrease energy consumption..

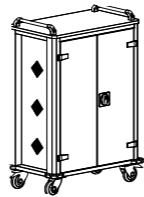

TECHNICAL SPECIFICATION

	
Designation	WNT 33
Code	WNL0917050604
Height (mm)	1050
Width (mm)	730
Depth (mm)	440
Number of compartments	32 tablets + 1 laptop



SCHOOL FURNITURE E-CLASS



SCHOOL DESKS

Q8 SCHOOL DESK

Very functional school desk with stable and rigid construction, equipped with feet adjustable ~15 mm.

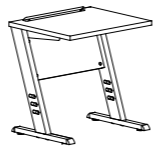

TECHNICAL SPECIFICATION

Q8 School desk		
Designation	Q8	Q8B
Code	XXXP 010029C	XXXP 010029D
Height (mm)	720	760
Width (mm)	700	800
Depth (mm)	580	700



SOCIAL FURNITURE

LOCKERS FOR LAPTOPS / MOBILE PHONES

LAPTOP LOCKERS

Laptop lockers are designed to secure laptops and to charge their batteries during storage. Inside the body there is a power strip mounted. Laptop's locker without electric installation is also available.

AND MOBILE PHONES LOCKERS

Lockers to store mobile phones are used in the pass control offices, agencies, institutions, libraries, reading rooms and other places where mobile phones are forbidden. These lockers can also be used as key deposits.



TECHNICAL SPECIFICATION

Laptop locker		
Designation	Locker for laptops SZNL 4110	
Code	SZNL 0101010101	SZNL 0101010104
Height (mm)	1800	
Width (mm)	400	
Depth (mm)	500	
Number of compartments	10	
Description	Locker without wiring	Locker with wiring



WSS locker for mobile phones										
	Designation	WSS 5	WSS 10	WSS 20	WSS 30	WSS 35	WSS 50	WSS 55	WSS 60	WSS 80
Code	WSS 06010601	WSS 01010101	WSS 02010201	WSS 03020301	WSS 07010701	WSS 03030801	WSS 03040901	WSS 04030401	WSS 05030501	WSS 08031001
Height (mm)	780			930	780	1530	1680	1530		
Width (mm)	210	390	750	930	1290	930		1110	1470	1650
Depth (mm)	200			200						
Number of compartments	5	10	20	30	35	50	55	60	80	90

SOCIAL FURNITURE

SOCIAL FURNITURE WITH MDF DOORS

Lockers with MDF doors are perfect combination of excellent technical parameters of a metal cabinet with aesthetics and ecology of a MDF board.

MDF is an ideal substitute of wood with no structural imperfections such as knots or cracks which are typical for wood. Unified both composition and density makes it an ideal material. The use of colourful or wood-based fronts with MDF gives the wardrobe locker the effect of lightness, comfort and a unique appearance

The doors of high quality laminated MDF board.

Galvanized hinge strips were used.



AVAILABLE COLOURS OF MDF DOORS



K 2081
SPARTA



F 7024
SAFFRON

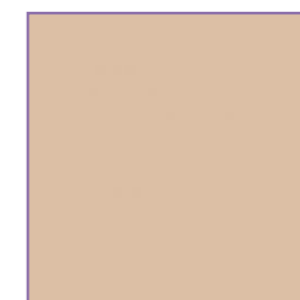

F 7858
PUMICE



F 2828
TROPICAL BLUE



F 7845
SPECTRUM RED



K 7024
BIRCH



K 7016
FINN BEECH



SOCIAL FURNITURE

SOCIAL LOCKERS WITH MDF DOORS

The locker has ventilation holes which provide proper air circulation. The bottom of the locker or base is protected against corrosion.

Bodies of the lockers are made of 0.8 - 1.0 mm thick high quality steel.

Covered with high-quality powder coat.

The standard cylindrical lock with blocking in point.

SUS wardrobe locker with MDF doors						
	Designation	SUS 312	SUS 314	SUS 315	SUS 322	SUS 324
Code	NSUM 0106070104	NSUM 0116070101	NSUM 0121070101	NSUM 0107070104	NSUM 0117070101	NSUM 0122070101
Height (mm)	1800		1800			
Width (mm)	300		300	600		
Depth (mm)	490		490			
Number of compartments	2	4	5	4	8	10

SUS wardrobe locker with MDF doors						
	Designation	SUS 412	SUS 414	SUS 415	SUS 422	SUS 424
Code	NSUM 0306070104	NSUM 0316070101	NSUM 0321070101	NSUM 0307070104	NSUM 0317070101	NSUM 0322070101
Height (mm)	1800		1800			
Width (mm)	400		400	800		
Depth (mm)	490		490			
Number of compartments	2	4	5	4	8	10

SUM wardrobe locker with MDF doors		
	Designation	SUL 41
Code	NSUM 0606070104	NSUM 0607070104
Height (mm)	1800	
Width (mm)	400	800
Depth (mm)	490	
Number of doors	2	4

SUM wardrobe locker with MDF doors				
	Designation	SUM 310	SUM 320	SUM 410
Code	NSUM 0101070102	NSUM 0102070102	NSUM 0301070103	NSUM 0302070103
Height (mm)	1800			
Width (mm)	300	600	400	800
Depth (mm)	490			
Number of units	1	2	1	2

SOCIAL FURNITURE

CANTEEN LOCKERS

Canteen lockers to store food products and personal items are perfect choice for such places as canteens or buffets.

Thanks to specially designed holes, it is possible to hang the lockers on the wall and to screw the lockers one to another to make bigger sets.

Each compartment is equipped with place for nameplate indicating the owner of the compartment. Each compartment with 2 keys. There is a possibility of ordering "Master" key that is able to open every compartment. Additionally the lockers are equipped with slanted top that helps maintain cleanness.

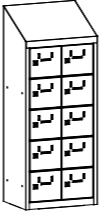
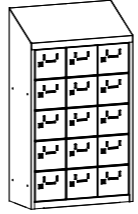
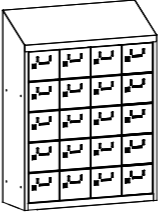
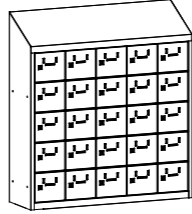

TECHNICAL SPECIFICATION

Canteen lockers					
Designation	SUS 215W	SUS 225W	SUS 235W	SUS 245W	SUS 255W
Code	SUS 0821050601	SUS 0822050601	SUS 0823050601	SUS 0824050601	SUS 0825050601
Height (mm)	1090		1090		
Width (mm)	240	430	620	810	1000
Depth (mm)	300		300		
Number of compartments	5	10	15	20	25

SOCIAL FURNITURE

KBS LOCKERS FOR CLEANING PURPOSES

For easy, safe and pleasant work...

KBS locker is a very practical type of metal furniture both for the distribution of safety products and to store dirty clothes.

Each compartment is closed with an independent key, and common frame allows to open all the lockers at the same time.

The person distributing safety materials has an access to all the compartments, and thanks to this he or she can control the stock and regularly restock them.

The main advantage of KBS lockers is a significant reduction of industrial safety products, and thus reducing costs. Modules of the locker for dirty clothes allow throwing dirty clothes through the opening slot easily.

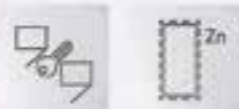

TECHNICAL SPECIFICATION

KBS cabinet with compartments	KBS 1		KBS 2		KBS 3		KBS 4	
	Code	KBS 01050201	Code	KBS 03050601	Code	KBS 02050201	Code	KBS 04050601
Designation	KBS 1		KBS 2		KBS 3		KBS 4	
Code	KBS 01050201		KBS 03050601		KBS 02050201		KBS 04050601	
Height (mm)	1900		1900		1900		1900	
Width (mm)	1225	820	840	435	840	435	435	
Depth (mm)	500		500		500		500	
Number of compartments	22 + compartment		22		11 + compartment		11	

Facilitate the work

Provides easy access to safety products and / or storage of dirty clothes.

Savings

Reduces the cost of safety products.

Control

Control of safety products consumption.

Functionality

A possibility of giving back and collecting new products.

SOCIAL FURNITURE

SMD CABINETS FOR CLEANING STAFF

Multifunctional cabinets are used to store clothes, household cleaners, buckets, brushes, etc. They facilitate the work of social workers and the cleaning services.

FUNCTIONALITY

- Depending on the needs SMD cabinet is equipped with:
- 4 non-adjustable shelves (SMD 60) or
 - Compartment with shelves and wardrobe section (SMD61) or
 - Compartment with shelves and compartment for a bucket and a brush (SMD 62).

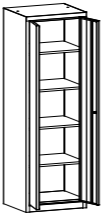
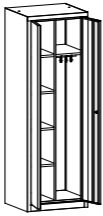
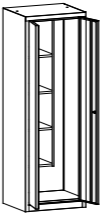

TECHNICAL SPECIFICATION

SMD cabinet for cleaning staff			
	Designation	SMD 60	
Code	SAU 0401030201	SAU 0401030401	SAU 0401030501
Height (mm)	1800		1800
Width (mm)	600		600
Depth (mm)	500		500



SOCIAL FURNITURE

MPO METAL RECYCLING BIN

Containers designed for internal use for various wastes: plastic, paper, glass. The body made of 0,8-1,0 mm thick steel, covered with structure powder coating. Slanted top prevents wastes from piling on the top of the container.

Self-closing lids prevent odours from emitting and close the containers in an aesthetic way.

Containers allow gathering wastes in 120-litre disposal bags or in internal galvanized metal containers of following dimensions: 700x295x357 mm (option at an extra cost).

Access to containers is simple thanks to frontal winged doors locking with a free-turning latch lock with a possibility of padlock locking.

Extendable frame for disposal bags placed on full-extension ball bearing slides facilitates the access to disposal bags that are placed on a frame by pressing it down with upper part of the frame mounted on hinges.



MPO metal recycling bin		
Designation	MPO 01r	MPO 01k
Code	PNO 0101010301	PNO 0101010201
Height (mm)	1220	
Width (mm)	400	
Depth (mm)	450	
Number of units	1	
Equipment	1 extendable frame	1 bin

MPO 02r	MPO 02k	MPO 02rk	MPO 03r	MPO 03k	MPO 03rk	MPO 03kr
PNO 0201010301	PNO 0201010201	PNO 0401020101	PNO 0301010301	PNO 0301010201	PNO 0301010601	PNO 0301010501
1220			1220			
800			1200			
450			450			
2			3			
2 extendable frames	2 bins	1 extendable frame + 1 bin	3 extendable frames	3 bins	2 extendable frame + 1 bin	2 bins + 1 extendable frame

Galvanized bin	
Designation	MPO k Galvanized container
Code	XPNO 01010101
Height (mm)	700
Width (mm)	295
Depth (mm)	357



SOCIAL FURNITURE

LOCKERS FOR FIRE FIGHTERS

Lockers for fire fighters are used to store clothes that fire fighters used during a fire fighting action.

The lockers are equipped with:

Corrosion protection - all locker made of galvanized steel.

For better air circulation it is possible to place the locker on the bench.

We produce lockers for firefighters and policemen for every European market.

We would like to present the lockers produced for customers' special requests.



Lockers for firefighters		
Designation	SUS 41	SUS 42
Code	SST 07010201	SST 08010201
Height (mm)	1950	
Width (mm)	400	800
Depth (mm)	550	
Equipment	a bar for clothes hooks helmet holder	



shelf



compartment closed with cylinder lock



storage handle for helmets

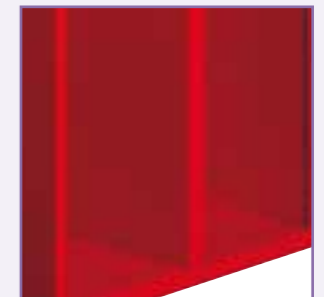

perforated bottom

SPECIAL PRODUCTS





SOCIAL FURNITURE

ARMY WARDROBES

Military wardrobes designed according to requirements of Regional Infrastructure Administration/Military Infrastructure Administration. They are used to store quarter equipment.

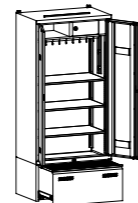

TECHNICAL SPECIFICATION

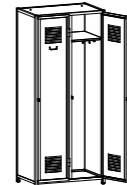
Army wardrobes			
Designation	WP2-40	Sum 421 military 27719	Sum 421 military 27789
Code		SUM 0701030201D56	SUM 0701030201D61
Height (mm)	2225	1850	1850
Width (mm)	1000	850	850
Depth (mm)	600	490	520
Equipment	Winged doors with code lock with 10000 combinations, fixed shelf with box closed with code lock with 1000 combinations; 3 shelves movable on the height; metal chrome-plated bar with movable hooks with possibility of mounting on 3 heights. Extendable drawer with lid closed with code lock with 1000 combinations. The inside of the drawer divided with vertical partition: 1 movable shelf in right compartment; gas servomotors prevent the lid from self-closing.	- left + right doors, - metal bar, - 4 hooks for clothes (2 per compartment), - body made out of angle bar 25x25x3 mm and 1,0 mm thick steel.	- right doors, - metal bar, - 4 hooks for clothes (2 per compartment), - butt hinges - body made out of angle bar 25x25x3 mm, tee 30x30x4 mm and 1,0 mm thick steel.

SOCIAL FURNITURE

LOCKERS WITH HEATING AND VENTILATION FOR CLOTHES' DRYING

LOCKERS WITH HEATING AND VENTILATION

Lockers with heating and ventilation were designed to dry wet clothes, shoes and gloves in closed rooms. This is a perfect solution wherever the environmental conditions cause dampness. These may be: construction sites, uniformed services, waterworks, railways, airports, mines, walk-in freezers, skiing resorts and many other.

The lockers are made out of powder coated steel sheet. They are equipped with connection terminals that enable connecting of ventilation duct.

There are several combinations of available lockers for clothes drying:

- locker with ventilation and socket enabling connection of 3 lockers in string,
- locker with heating and ventilation,
- locker with internal partitions in compartments, with heating and ventilation,
- locker with heating, ventilation, time switch and socket enabling connection of 3 lockers in string.

Safety:



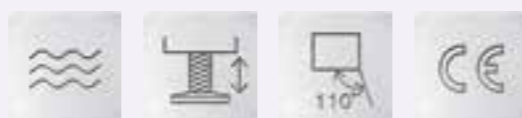

- CE symbol,
- IP 21 resistance class,
- thermal protection against overheating.

CABINET FOR CLOTHES AND SHOES' DRYING

Cabinet for drying clothes and shoes for 10 working sets of clothing. It is equipped with a bar to hang damp clothes and bottom compartment with 20 pipes for damp shoes. Long pipes enable hanging high working boots. Cabinet with adjustable feet and handles on the sides to move the cabinet easily. Plastic transparent curtain protects from excessive heat loss and enables an easy access to the dried clothes. Cabinet made out of fire galvanized steel sheet.

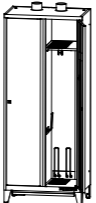

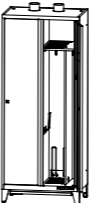
TECHNICAL SPECIFICATION

Locker with heating and ventilation				
	Designation	SUM 421	SUM 421	SUM 421
Code	SUMW 0701030214	SUMW 0701030215	SUMW 0701030219	SUMW 0701030230
Height (mm)	2006		2006	
Width (mm)	800		800	
Depth (mm)	490		490	
Equipment	- ventilation and heating 1000 W	- ventilation and heating 1000 W, - internal partitions in compartments	- ventilation and heating 1000 W, - internal partitions in compartments, - a time switch, - power socket to link 3 lockers	- ventilation, - power socket to link 3 lockers

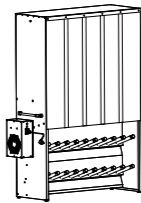
Cabinet for clothes and shoes' drying	
Designation	Cabinet for clothes and shoes' drying
Code	XXXXP 020055
Height (mm)	1971
Width (mm)	1515
Depth (mm)	500
Equipment	- a bar for clothes, - 20 pipes for shoes, - 2 heating and ventilation modules, - 2 handles to move the cabinet, - leveling feet

SOCIAL FURNITURE

SPORTS FURNITURE

SPORT WARDROBE LOCKER

The door locked in 1 or 3 points. Door equipped with a opening limiter.

Locker's equipment:

- the right part – equipped with 3 fixed shelves,
- the left part - equipped with 1 lockable compartment and a bar.

At the bottom of the cabinet there is one compartment for shoes, together with extended basis. The door is equipped with a metal container for small items and a set of 3 hooks for towels and clothes.

All shelves are spaced every 200 mm.

SPORTS CABINET FOR COACHES

The cabinet has possibility of easy configuration of the following equipment:

- hooks i.e. for jump ropes, hula-hoops,
- shelves (for plastrons),
- frame drawer with dividers (for bow-shaped handles, javelins),
- possibility of mounting on the drawer a compartment for stopwatches, whistles and other small items.

These elements mentioned above are our standard offer and are height adjustable. Perforated door, with the full opening, lockable in 2 points.

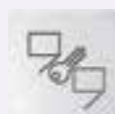

TECHNICAL SPECIFICATION

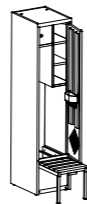
Sport wardrobe locker					
	Designation		Sum 410 sport	Designation	Sbm 212 for sports equipment
	Code	SUM 0601020102B80		Code	SNSS 11032037
	Height (mm)	1800		Height (mm)	1990
	Width (mm)	400		Width (mm)	1200
	Depth (mm)	490		Depth (mm)	500
	Number of units	1		Number of units	1



SOCIAL FURNITURE

TABLES, BENCHES, CHAIRS AND STANDS

A perfect supplement for changing rooms and social rooms are benches, stands, chairs and tables.



single benches - frame made of tubular steel (ŁO)



single benches - frame made of closed profile (Łsz 3, Łsz 3a)



single benches made of solid wood – folding metal frame (BS)



one-side benches with support and hooks (Łsz 1, Łsz 1a)



double-side benches with support and hooks (Łsz 2, Łsz 2a)

TECHNICAL SPECIFICATION

Tables, benches, chairs and hangers								
	Łsz 3		Łsz 3a		Łsz 1		Łsz 1a	
	Łsz 2		Łsz 2a		Łsz 3		Łsz 3a	
	LSZ 050205		LSZ 060205		LSZ 010101		LSZ 020101	
	LSZ 030102		LSZ 040102		1650		1650	
	405		405		1000		1500	
Designation	Łsz 3		Łsz 3a		Łsz 1		Łsz 1a	
Code	LSZ 050205		LSZ 060205		LSZ 010101		LSZ 020101	
Height (mm)	405		405		1000		1500	
Width (mm)	1000		1500		380		730	
Depth (mm)	355		355		1000		1500	



Tables, benches, chairs and hangers												
	KD		ŁO 12		ŁO 16		ŁO 20		Bench BS		Table BS	
	KKD		LO 01010101		LO 02010101		LO 03010201		ŁAWKA BS		STÓŁ BS	
	780/450		460		460		460		480		780	
	460		1200		1600		2000		2200		2200	
	500		440		440		440		250		600	
Designation	KD		ŁO 12		ŁO 16		ŁO 20		Bench BS		Table BS	
Code	KKD		LO 01010101		LO 02010101		LO 03010201		ŁAWKA BS		STÓŁ BS	
Height (mm)	780/450		460		460		460		480		780	
Width (mm)	460		1200		1600		2000		2200		2200	
Depth (mm)	500		440		440		440		250		600	
Description	chair		garden bench		garden bench		garden bench		garden bench		garden table	
											WPPS 1	
											PPSW 010101	

SCHOOL FURNITURE

SCHOOL CHAIRS

STANDARD School chair
Size 0-4 K06 5-7 K07,
frame out of square profile 20x20 mm,
birch plywood.

STANDARD School chair with movable desktop
Size 5-7 K16,
frame out of square profile 20x20 mm,
birch plywood.

BOLEK School chair
size 1-4 Ø 22 mm K08,
size 5-7 Ø 25 mm K09,
birch plywood.

BOLEK School chair with desktop
size 1-4 Ø 22 mm K30,
size 5-7 Ø 25 mm K31,
birch plywood.

Height scope according to PN-EN 1729:2007-1

Number	Range of height	Colour mark
1	93 - 116 cm	Orange
2	108 - 121 cm	Purple
3	119 - 142 cm	Yellow
4	133 - 159 cm	Red
5	146 - 176,5 cm	Green
6	159 - 188 cm	Blue
7	174 - 207 cm	Brown



STANDARD school chairs



BOLEK school chairs

VARIOUS TYPES



STANDARD school chair



STANDARD school chair with movable desktop



BOLEK school chair



BOLEK school chair with desktop

SCHOOL FURNITURE

SCHOOL DESKS BLACKBOARDS

DESKS

STANDARD School desk
single, 75x50 cm,
size: 1-4 S18 5-7 S21,
frame made of 25x25 mm square profile,
18 mm thick laminated board,
1 mm or 2 mm thick PVC veneer.

STANDARD School desk
double, 130x50 cm,
size: 0-4 S24 5-7 S25,
frame made of 25x25 mm square profile,
18 mm thick laminated board,
1 mm or 2 mm thick PVC veneer.

STANDARD School desk
single, 75x50 cm,
size: 1-4 Ø 30 mm S104,
size: 5-6 Ø 30 mm S105,
double, 130x50 cm,
size: 1-4 Ø 30 mm S102,
size: 5-6 Ø 30 mm S103,
18 mm thick laminated board,
1 mm or 2 mm thick PVC veneer.
with adjustable leveling feet.

School desk with adjustable height
size: 0-2, 1-3, 2-4, 3-6, 5-7,
frame made of 25x25 mm square profile,
18 mm thick laminated board,
1 mm or 2 mm thick PVC veneer.
single 75x50 cm S30,
double 130x50 cm S23,
triple 180x50 cm S28,
with adjustable leveling feet.

BLACKBOARDS

We offer also white magnetic boards. There is possibility to order blackboards with rulings: check, line, 3-line, stave, ordinates.



STANDARD single school desk,
frame made of square profile



STANDARD double school desk,
frame made of square profile



school desk with adjustable height,
frame made of square profile



STANDARD school desk,
frame made of Ø 30 mm tubular steel

BLACKBOARDS



single green board 1700x1000 mm



TRYPTYK green board 3400x1000 mm



green board with a stand 1700x1000 mm,
height of the stand 1980 mm

OFFICE FURNITURE

SBM OFFICE CABINETS WITH WING DOORS

Doors with hidden hinges. Door handle with security lock. Locking in 2 points (top and bottom).

CABINETS' ADVANTAGES:

- extensive equipment as standard,
- 16 RAL colours without extra charge,
- various sizes and equipment,
- adjustable shelves,
- various types of cabinets,
- various price levels.



CABINETS' ADVANTAGES



extensive equipment
as standard



16 RAL colours without
extra charge



various sizes and equipment



adjustable shelves



various types of cabinets



various price levels



OFFICE FURNITURE

SBM OFFICE CABINETS WITH WING DOORS

We offer a wide range of top cabinets. The width of top cabinets is adjusted to the width of standard cabinets. Available top cabinets:
 - 465 mm high – for 2 low rows of files,
 - 810 mm high – for 2 rows of binders.
 Top cabinets have one shelf adjustable every 25 mm ± 3 positions from the center position.

Designation	SBM 101 M	SBM 102 M	SBM 103 M	SBM 107 M	SBM 201 M	SBM 202 M	SBM 203 M	SBM 212 M
Code	SBM 01022203	SBM 02022303	SBM 03022303	SBM 04022303	SBM 01032204	SBM 02032304	SBM 03032304	SBM 04032304
Height (mm)	1040		1040		1990			
Width (mm)	600	800	1000	1200	600	800	1000	1200
Depth (mm)	435		435					
Cabinet's capacity	2 rows of binders		2 rows of binders		5 rows of binders			
Number of shelves	2		2		4			

Designation	SBM 204 M	SBM 213 M	SBM 206 M	SBM 215 M
Code	SBM 03032305	SBM 04032305	SBM 03032306	SBM 04032306
Height (mm)	1990		1990	
Width (mm)	1000	1200	1000	1200
Depth (mm)	435		435	
Cabinet's capacity	4 rows of binders + locker		1 row of binders + 4 in halves	
Number of shelves	3		4 shelves + wardrobe compartment	

For an extra charge, cabinets can be equipped with leveling feet, screwed to the bottom. They are regulated from the inside of the cabinet.

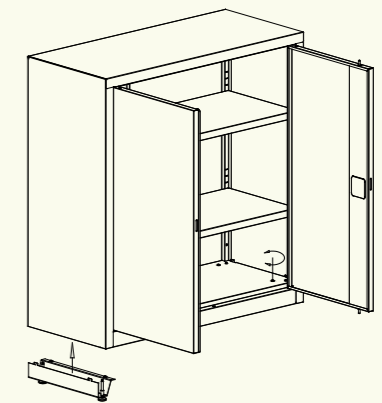

Designation	SBM 401 M	SBM 402 M	SBM 403 M	SBM 405 M	SBM 801 M	SBM 802 M	SBM 803 M	SBM 804 M
Code	SBM 01012202	SBM 02012302	SBM 03012302	SBM 04012302	SBM 01122202	SBM 02122302	SBM 03122302	SBM 04122302
Height (mm)	465		465		810			
Width (mm)	600	800	1000	1200	600	800	1000	1200
Depth (mm)	435		435					
Cabinet's capacity	2 low rows		2 low rows		2 rows of binders			
Number of shelves	1		1		1			

WORKSHOP FURNITURE

STW WORKSHOP TABLES

Our STW workshop tables combine high quality, strength and functionality.

STW Workshop tables are designed for mechanical workshops, tool departments, as well as small mechanical workshop and individual clients.

Workshop tables in combinations with metal cabinets, tool walls and storage racks provides great work organization.

Their diversity guarantees that they are perfectly fitted to the customer's individual needs.



TECHNICAL SPECIFICATION

Workshop tables							
Designation	Stw 111	Stw 121	Stw 321	Stw 322	Stw 323	Stw 324	Stw 311
Code	STWS 01010201	STWS 02010202	STWS 02010103	STWS 02010104	STWS 02010305	STWS 02010306	STWS 01010207
Height (mm)	850		850				
Width (mm)	600	1200	1200	1200	1200	1200	600
Depth (mm)	600		600				
Dimensions of tabletop in mm (h x w x d)	30 x 600 x 600	30 x 1200 x 600	30 x 1200 x 600	30 x 1200 x 600	30 x 1200 x 600	30 x 1200 x 600	30 x 600 x 600



Workshop tables									
Designation	Stw 122	Stw 112	Stw 113	Stw 114	Stw 401	Stw 402	Stw 403	Stw G 45	Stw G 47
Code	STWS 02020211	STWS 01020207	STWS 01020212	STWS 01020113	STWS 04010209	STWS 05010310	STWS 06010310	GST 02020202	GST 01010201
Height (mm)	750		850					725 - 920	
Width (mm)	1200	600	600	600	1200	1600	200	1200	1000
Depth (mm)	600		600		750		600		
Dimensions of tabletop in mm (h x w x d)	30 x 1200 x 600	30 x 600 x 600	30 x 600 x 600	30 x 600 x 600	40 x 1200 x 750	40 x 1600 x 750	40 x 2000 x 750		

WORKSHOP FURNITURE

SZW WORKSHOP LOCKERS FOR TOOLS

ŚNN TOOL WALLS

It is essential to have the most necessary tools within reach. This can be ensured by our tool walls. Tool walls for self assembly.

SZWN WORKSHOP TROLLEY

- The workshop trolleys are equipped with:
- tops made from hardwood plywood,
 - all drawers locked with central lock,
 - drawers on ball bearing slides (maximum load capacity of 50 kg per drawer),
 - doors locked with a cylindrical lock,
 - two swivel wheels.

SZWG CABINET

Workshop locker on swivel wheels (2 with brakes). The top part made of perforated steel sheet (back and side walls), the bottom part with a shelf and 2 drawers. Set of hooks - according to the client's needs (at an extra cost).

SZW WORKSHOP CABINET WITH DRAWERS

Szw lockers provide stable construction, central lock, anti lift system (preventing from opening more than one drawer at a time).

Maximum load capacity per drawer: 75 kg.

On customer's request the top can be covered with: rubber, plywood in metal frame or acid-proof steel sheet.

Drawer partitions are also available, allowing for dividing the drawer into 5 rows. Every row is equipped with 2 galvanized partitions.



TECHNICAL SPECIFICATION

Tool walls	
Designation	Śnn 300
Code	SNN 010101
Height (mm)	600
Width (mm)	1195
Depth (mm)	16
Equipment	-base board – 3 pcs, single hook (58 mm) -5 pcs, long slot holder for the screwdrivers – 1 pc, holder with circular holes – files – 1pc, holder with rectangular holes – chisels – 1 pc, holder for a drill – 1 pc, holder for the wrench – 1 pc, holder with circular holes for screwdrivers – 1 pc, holder for V container – 2 pcs, single holder – 4 pcs.



Szw 301

Workshop trolleys			
Designation	SzWN 251	SzWN 252	SzwG 43
Code	GWJ 0101020702	GWJ 0101010802	GWJ 03020366
Height (mm)	928		1930
Width (mm)	961		815
Depth (mm)	600		600
Equipment	5 drawers (including one deep drawer)	10 drawers (including 2 deep drawers)	- On wheels – the top part made of perforated steel sheet (back and side walls). The bottom part with a shelf and 2 drawers.

Workshop cabinets with drawers			
Designation	Szw 301	Szw 302	Szw 305
Code	SZWL 0202010201	SZWL 0202010301	SZWL 0202010601
Height (mm)	1051	1051	1051
Width (mm)	1000	1000	1000
Depth (mm)	585	585	585
Height of drawers (mm)	width: 903 x depth: 435	width: 903 x depth: 436	width: 903 x depth: 437
Height of front	1 drawer 175 mm 2 drawers 225 mm 1 drawer 275 mm	1 drawer 75 mm 2 drawers 125 mm 2 drawers 175 mm 1 drawer 225 mm	7 drawers 75 mm 3 drawers 125 mm



De Raat
security products

De Raat Security Products NV
Gareelmakersstraat 10
B 2200 Herentals
België

+32 (0)14-23 23 71
info@deraat.be
www.deraat.eu